

Facility Timing Made Easy



► System Timing with the Tektronix Timing Display

With the advent of digital signals, system timing considerations have become simultaneously less critical and more important. While the effect of minor timing variations may be less noticeable than in a composite NTSC/PAL world, and digital signal processing devices may provide compensation for modestly mis-timed signals, these same devices have the potential to deliver signals with larger timing errors than typically encountered in the analog world.

Digital signal processing devices, such as video switchers, frame synchronizers, and a wide variety of sources, allow easy adjustment of signal timing to match whatever system they may be assigned. Timing may be automatically compensated by the receiving device, but often the signal must be manually matched into a system. The Tektronix Timing display provides an intuitive tool to make timing simple and easily understood.

In an analog video system, timing has been traditionally evaluated in terms of subcarrier phase and nanoseconds delay. Timing errors were corrected by adjusting cable length (about 1.5 ns/ft) or advancing or delaying the synchronizing signal to one of the signals to be matched. The adjustment, once made, was often fixed and, hopefully, never touched again. The coarse-timing-match was observed with a waveform monitor and the fine-timing-match with a vectorscope,

both switching from one signal to the other signal while locked to an external reference. This method of observation worked very well with timing differences of one line or less. A more complex evaluation of the vertical interval and color burst phase was required for comparison of analog signals more than one line delayed or advanced.

While digital signals are more tolerant of small timing errors, the devices that process digital video tend to create longer delays and may be adjusted over a much wider range. Digital signal timing has not been easy to observe using conventional waveform and vector displays that tend to look very much the same for different lines, fields, and frames. Traditional techniques have included observation of similar picture elements using an under-scanned picture monitor, or observation and position comparison on the display of an externally referenced analog waveform display of the digital "xyz" word in the EAV and SAV packets. The picture monitor technique provides a rough indication of timing match between two signals, and the comparison of the "xyz" word allows a fine horizontal position match, but a combination of the two methods is required for a complete answer. Further, these timing methods do not provide a timing error value easily conveyed verbally to the person adjusting the timing at a remote source.

Facility Timing Made Easy

► Technical Brief

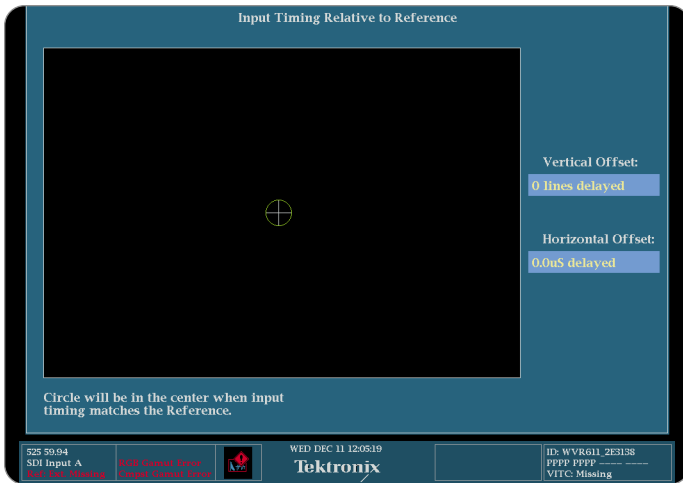

► *The new, patented Tektronix Timing display.*

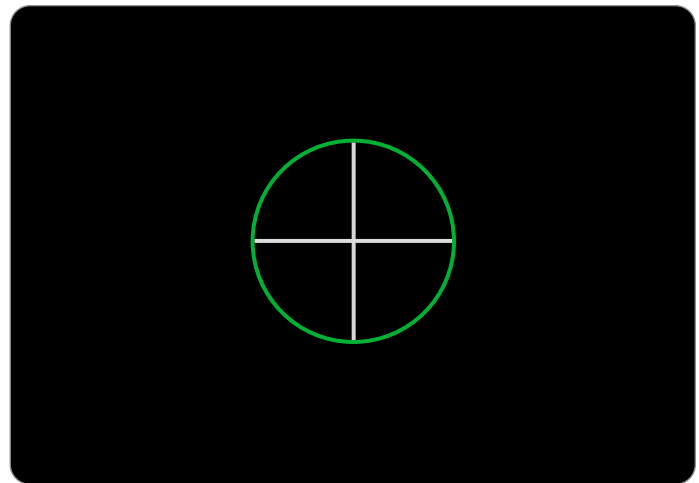

► *Graphical indication of a signal, timed perfectly with respect to reference.*

The Tektronix Timing display offers a tool to easily observe and directly measure the timing difference between two signals as the timing is corrected. A visual indicator shows the magnitude and direction of the timing error and moves toward a null position as the timing error is corrected. Digital or analog signals may be correctly timed using this graphic display, with final match performed using numeric Vertical and Horizontal readouts. Once timed, the digital signal is ready to use, and the analog signal is ready for a final subcarrier phase adjustment using the WVR600 Series vectorscope display.

Tektronix Timing Display

The patented Tektronix Timing display provides a unique timing comparison between a house reference signal and a digital or analog television signal, and eliminates the ambiguity present in waveform monitor and vectorscope measurements when timing differences approach multiples of a field or line. Timing difference is displayed numerically in terms of vertical and horizontal offset of the signal being timed to the house reference signal. In addition, an innovative graphic target icon clearly indicates the timing relationship over the full color frame, displaying gross error in terms of relative screen position.

The Timing display's target icon takes advantage of the eye's preference for symmetry and screen position, as opposed to color, contrast, size, or even focus. For example, we can accurately divide a circle into four

quadrants and the eye will tell us each quadrant is the same size and shape. If the division of the circle is even a little off-center, the eye quickly detects an imbalance in the area of each quadrant. The graphic nature of the television picture display provides an ideal palette for this timing comparison. If we display quadrant dividers in a fixed position locked to the house reference signal, and display the circle locked to a digital or analog video signal, it is very easy to see a timing relationship.

Timing differences are indicated by vertical and/or horizontal displacement between the circle and the reference quadrant dividers. The vertical display screen represents the full range of possible timing error, up to a full color frame. The horizontal screen dimension represents the full line. If the green circle were below and to the left of the target, that signal would be delayed by a number of full lines plus a part of an additional line as indicated by the numeric readout. The vertical and horizontal numeric readout follow the timing adjustment convention of the video source.

Very small horizontal timing differences, as small as 90 nS; and vertical timing differences as small as five lines are easily observed with this full color frame graphic display. Large timing differences are easily "walked" in, bringing the circle, representing the video being timed, into coincidence with the stationary house reference target in the center of the display. As the adjusted signal comes into timing alignment,

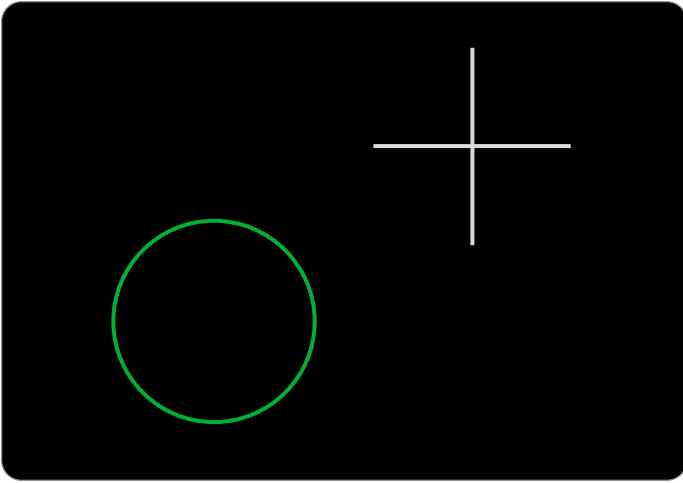

▶ *Example of a signal delayed vertically but advanced horizontally. Corrections should be applied to overlay the circle atop the crosshair.*

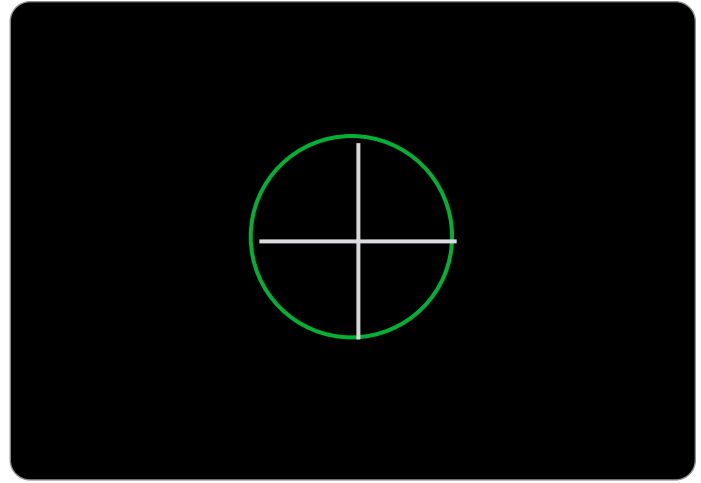

▶ *Timing just slightly off, yet easily detected via this graphical presentation.*

the eye discerns the finest adjustment as bringing the circle into perfect symmetry, or balance around the target divider. Once the target icon is brought into symmetry, it is easy to make fine vertical and horizontal timing adjustments by referring to the numeric readouts. For composite signals the vectorscope display would then be used for the final adjustment of subcarrier phase.

New Tools for New Signals

A timing difference of almost exact line multiples is very difficult to detect with a traditional CRT waveform display. To avoid brightness flicker, a CRT waveform monitor without digital storage will display first one line of a reference signal, then overlay the next line of the alternate signal. This one-line timing difference between the horizontal sync edges of two signals being matched would be of little consequence if we knew they could not be more than a few microseconds out of time. However, we cannot be assured of this when digital delays such as frame synchronizers and digital video processors are present, and different reference sync generators control the various signals in a television plant.

The Tektronix Timing display measures timing differences and presents the error just as it would affect the signal. The most obvious picture effect of a mis-timed digital signal is position shift. This causes other problems including mis-registration or display instability when one video

picture is mixed with another. Of course, you could generate the same picture, with specific reference marks, and visually observe how the two pictures registered. This method would work in a crude sort of way, perhaps with picture breakup as two untimed signals were superimposed. Integer field delays would be particularly difficult to observe using just a picture monitor because the monitor will tend to synchronize as the fields are alternated.

The Timing display improves on this technique, generating a stable reference target in the center of a display field locked to the house reference signal's synchronizing characteristics. A circle representing the signal to be adjusted is generated and positioned on the display screen to indicate relative timing. The reference target (representing house reference) and circle (representing video input A or B) are generated from the two signals, without the need for any special timing test signal.

Timing Adjustment Procedure

Connect a house reference signal with the desired system timing to the external reference input of the WVR600 Series rasterizer. Connect a digital or analog video signal whose timing is to be adjusted to the selected signal on input A or B of the instrument. Select the Timing display under the Measure button.

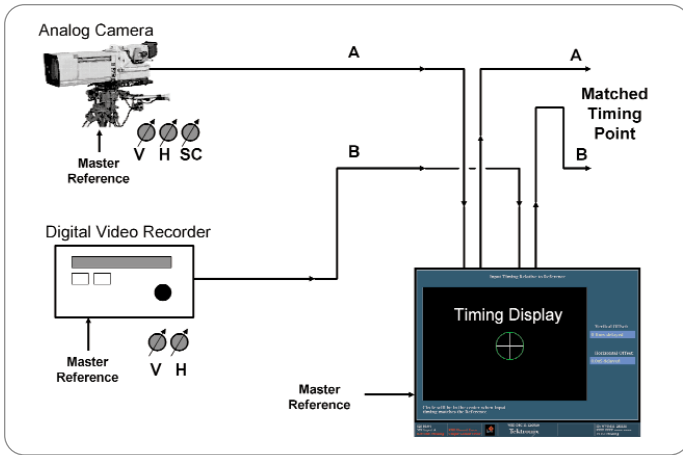

► An in-system view of the Tektronix Timing display.

The display screen will appear with the master reference signal timing represented by a white cross target in the center of the screen. The timing of the signal to be adjusted will be represented by a stationary white circle somewhere on the display. A timing match between the reference signal and either of the two signal inputs, A or B, is indicated by a perfect coincidence of the circle around the white reference target and null values of the vertical and horizontal timing readouts. The circle turns to green to graphically indicate timing null. If analog composite signals are being timed, the timing display will show vertical and horizontal timing, and the instrument's vectorscope display would be used to match the phase of the color subcarriers.

If the circle is not perfectly coincident with the reference target and timing readouts are not zero, adjust the vertical timing of the video source to time the signal to the same video line in the color frame. Then adjust horizontal timing to fit the circle cleanly around the reference target. Final touch-up adjustment is made using the numeric readouts of Vertical and Horizontal Timing. For analog composite signals, the one additional step would be to adjust system phase with the Vector display. Select the next signal source and repeat the adjustment.

Contact Tektronix:

ASEAN / Australasia / Pakistan (65) 6356 3900

Austria +43 2236 8092 262

Belgium +32 (2) 715 89 70

Brazil & South America 55 (11) 3741-8360

Canada 1 (800) 661-5625

Central Europe & Greece +43 2236 8092 301

Denmark +45 44 850 700

Finland +358 (9) 4783 400

France & North Africa +33 (0) 1 69 86 80 34

Germany +49 (221) 94 77 400

Hong Kong (852) 2585-6688

India (91) 80-2275577

Italy +39 (02) 25086 1

Japan 81 (3) 3448-3010

Mexico, Central America & Caribbean 52 (55) 56666-333

The Netherlands +31 (0) 23 569 5555

Norway +47 22 07 07 00

People's Republic of China 86 (10) 6235 1230

Poland +48 (0) 22 521 53 40

Republic of Korea 82 (2) 528-5299

Russia, CIS & The Baltics +358 (9) 4783 400

South Africa +27 11 254 8360

Spain +34 (91) 372 6055

Sweden +46 8 477 6503/4

Taiwan 886 (2) 2722-9622

United Kingdom & Eire +44 (0) 1344 392400

USA 1 (800) 426-2200

USA (Export Sales) 1 (503) 627-1916

For other areas contact Tektronix, Inc. at: 1 (503) 627-7111

Updated 20 September 2002

For Further Information

Tektronix maintains a comprehensive, constantly expanding collection of application notes, technical briefs and other resources to help engineers working on the cutting edge of technology. Please visit www.tektronix.com



Copyright © 2003, Tektronix, Inc. All rights reserved. Tektronix products are covered by U.S. and foreign patents, issued and pending. Information in this publication supersedes that in all previously published material. Specification and price change privileges reserved. TEKTRONIX and TEK are registered trademarks of Tektronix, Inc. All other trade names referenced are the service marks, trademarks or registered trademarks of their respective companies.

01/03 HB/XBS

25W-16527-0